

MOTOR LOCATION NOTES:
 THE MOTOR OF AN AMH MAT HOIST IS LOCATED AT THE CENTER OF THE HOIST LOCATION. ANY WIRING SHOULD BE ROUTED TO TAKE THIS INTO ACCOUNT, AND SHOULD BE WITHIN 36" OF THE MAT HOIST CENTER.

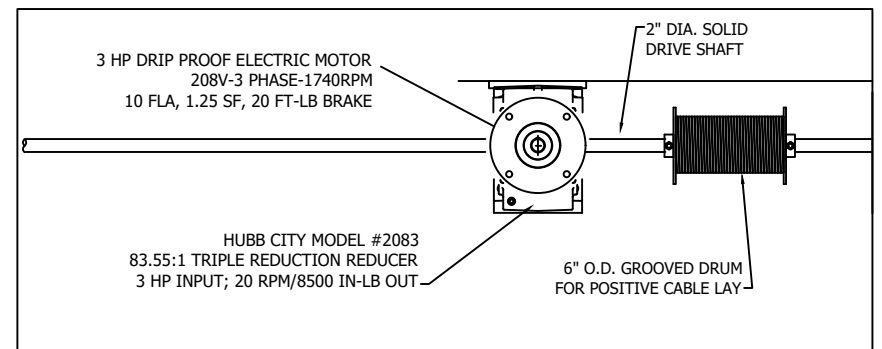

OPERATION NOTES:
 - ROLL MAT(S) INTO LIFT SLING
 - SECURELY HOOK SLING STRAPS TO LOAD BAR
 - OPERATE KEYSWITCH TO LIFT MATS TO STORAGE HEIGHT.
REVERSE OPERATIONS TO LOWER MATS FOR USE

6 WFx20 HOIST BEAM x 22' W/MOTOR, ETC.	=1100LBS
2" X 6" RECT. STEEL LOAD BEAM x 42'	= 630LBS
45' x 45' WRESTLING MAT (2025 SQ. FT x 1LB) QTY 2	=4050LBS
TOTAL WEIGHT	=5780LBS

VERIFY VOLTAGE:
 MOTOR IS AVAILABLE AS FOLLOWS -
208 V 3PH. 460 V 3PH.
 ADVISE AS TO TYPE

IMPORTANT NOTE:
 THE *ARCHITECT* MUST VERIFY THE LOCATION(S) OF ALL GYM EQUIPMENT AALCO MFG. CO. IS CONTRACTED TO SUPPLY, EG: BASKETBALL GOAL(S), GYM DIVIDER CURTAIN (S), WRESTLING MAT HOIST (S), BATTING/GOLF CAGE (S) VARIIFICATION OF ALL EQUIPMENT MUST BE MADE BY THE *ARCHITECT* BEFORE ANY FABRICATION MAY BEGIN. Approval
 Signature: X _____
 Printed Name: X _____ Date: _____

() REQUIRED MODEL #AMH
Scale: 1/4" = 1'-0"

NOTE:
 ALL STRUCTURAL CALCULATIONS FOR ADDITIONAL SUPPORT BEAMS TO JOISTS/WALL (BY OTHERS) **SHALL BE COMPLETED BY SUPPORT SUPPLIER.** FOR THIS ATTACHMENT METHOD TO WORK THE LOCATIONS OF THE BEAMS BY OTHERS IS CRITICAL & WIDTH OF BOTH BOTTOM & TOP CHORDS SHALL NOT EXCEED 6".